

YPOCC¹ | BASIC COLOR

Instruction Manual

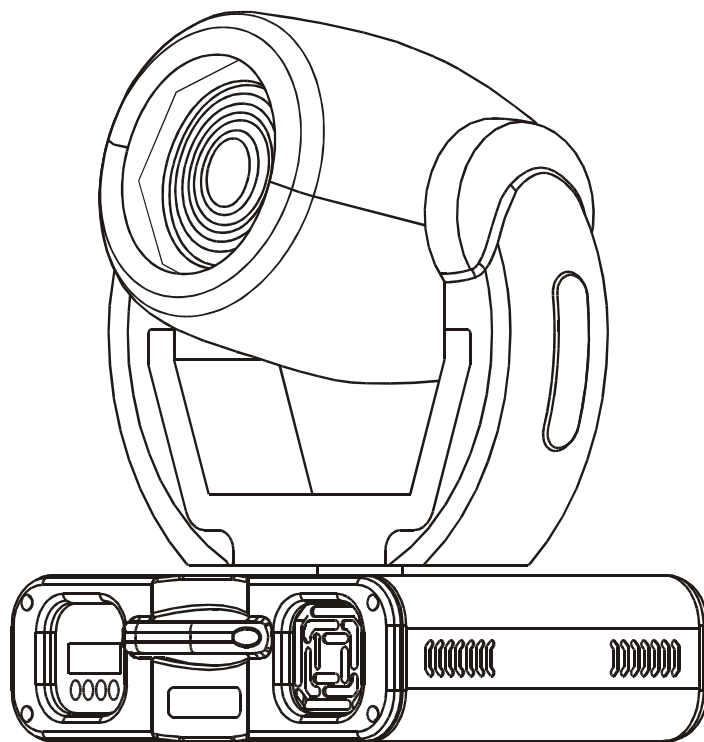

from software version 1.0
(instruction version 1.0)



GERMAN LIGHT
PRODUCTS

e-mail: service@glp.de
Internet: <http://www.GLP.de>

This side is intentionally unlabelled.

Table of contents

1	Description of Device	5
1.1	Safety Instructions.....	6
2	Preparation and Installation	7
2.1	Mounting	7
2.1.1	Clamps	7
2.1.2	Mounting plate	8
2.2	Secure the YPOC 250 COLOR.....	8
2.3	Connections	9
2.3.1	Power supply	9
2.3.2	DMX.....	9
2.4	Fuse	9
3	The Menu Field	10
3.1	Adjust the DMX- Address [D00 0].....	11
3.2	The Test Program [TEST].....	11
3.3	The Audio Program [AUD 1].....	11
3.4	Lamp On/Off [LAMP].....	12
3.5	Reset [RESE]	12
3.6	Running time of lamp and unit [TIME].....	12
3.7	Continuous Color Wheel [FCOL].....	12
3.8	Invert Pan Movement [RPAI].....	12
3.9	Invert Tilt Movement [RTL T]	13
3.10	Special Functions [SPEC]	13
3.10.1	Manual Drive [MANU].....	13
3.10.2	Lamp On automatically [LAPU].....	13
3.10.3	Lamp Off via DMX [ILOF].....	14
3.10.4	DMX Input [DMX 1]	14
3.10.5	Display [DISP]	15
3.10.6	Fixture Temperature [TEMP].....	15
3.10.7	Fan Control [FANS]	15
3.10.8	Adjustments and Calibrations [ADJU].....	16
3.10.9	Default Settings [DFSE].....	16
3.10.10	Feedback [FEE 1]	17
3.10.11	Correction of faults [EFL 1].....	17
3.11	Error and Information Messages.....	17

4	DMX Channel Selection (DMX Protocol)	18
5	Change the Lamp	20
5.1	Safety Regulations	20
5.2	Realize the Lamp Change.....	20
6	Maintenance and Cleaning the YPOC COLOR Basic	20
6.1	Safety Regulations	21
6.2	Circumference and Interval (rule-of-thumb)	21
6.3	Cleaning the Optical System.....	22
7	Technical Specification	23
8	Index	24

1 Description of Device

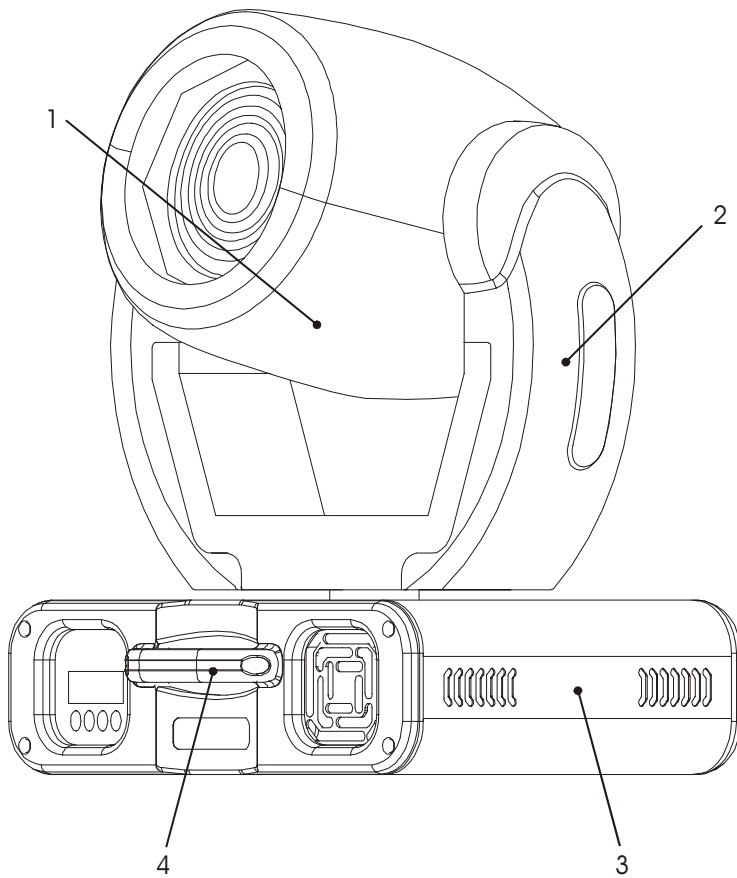

- 1. Moving Head
- 2. Arm
- 3. Base
- 4. Carrying handles

- 5. Up- button
- 6. Down- button
- 7. Enter- button
- 8. Mode- button
- 9. LED- Display
- 10. Software-Update connector

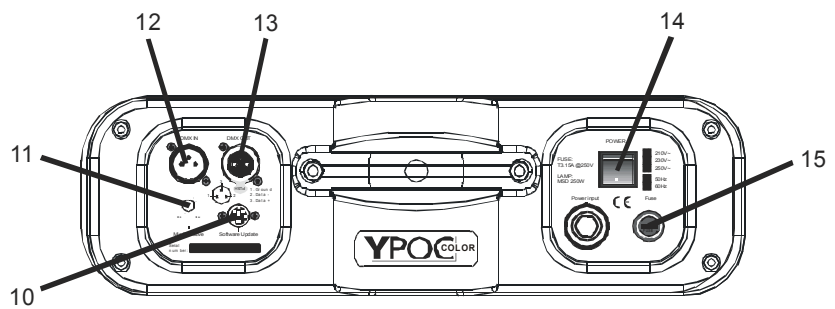

- 11. Microphone- Intensity
- 12. DMX- Input
- 13. DMX- Output
- 14. Power On/Off
- 15. Fuse F3,15 A
- 16. Fan (air inlet)

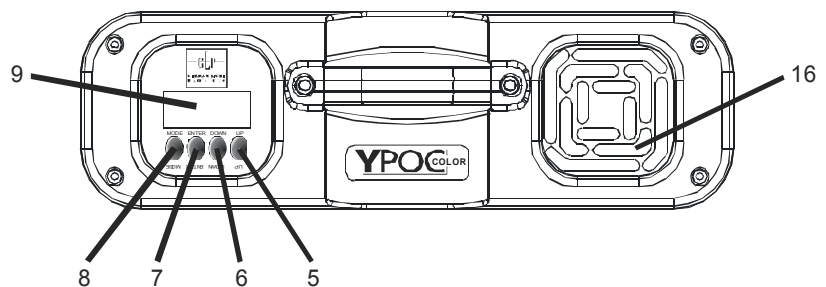

1.1 Safety Instructions



The **YPOC COLOR Basic** is a High-Tech Product. To guarantee a smooth operation, it is necessary to keep following rules. The manufacturer of this device will not take responsibility of damages through disregard of the information in this manual. Warranty adjustments will be canceled.

1. Make sure before putting into operation, that the fan and the air inlets are clean and not blocked by anything.
2. **Attention:** Don't touch the device during the operation. This can cause injuries or damages.
3. **Unplug the YPOC COLOR Basic from the AC outlet before any service.**
4. It is necessary to wait at least 30 minutes after disconnecting the AC before you open the **YPOC COLOR Basic**. Please do not touch the bulb of the lamp if you are not absolutely sure it is cold. **-DANGER OF BURNING-**
5. Never look directly into the beam of the lamp. You risk injury of your retina and blindness.
6. Pay attention of the maximum lamp operation time. You have to change it if the lamp shows any deformations or damages. The same is with all glass components, color filters, lenses and mirrors.
7. To allow a secure operation, follow also the Installation guide described in chapter 2. Operating the **YPOC COLOR Basic** without suited safety aids like Safety cables or clamps/hooks can increase the risk of an accident.
8. The installation should be done by qualified staff only. You need to pay attention to the common rules of technology that are not explicit mentioned in this manual.
9. Use only original spare parts. Any structural modification will cancel all warranty adjustments.

2 Preparation and Installation

2.1 Mounting

The **YPOC COLOR Basic** is fully operational whether it hangs or is mounted to the wall. It can also be operated while standing on the floor. Keep a safety distance of 0.5 m towards any easy inflammable materials (decoration etc.). Install a safety wire that can hold at least 10 times the weight of the fixture. Never use the carrying handles for secondary attachment.

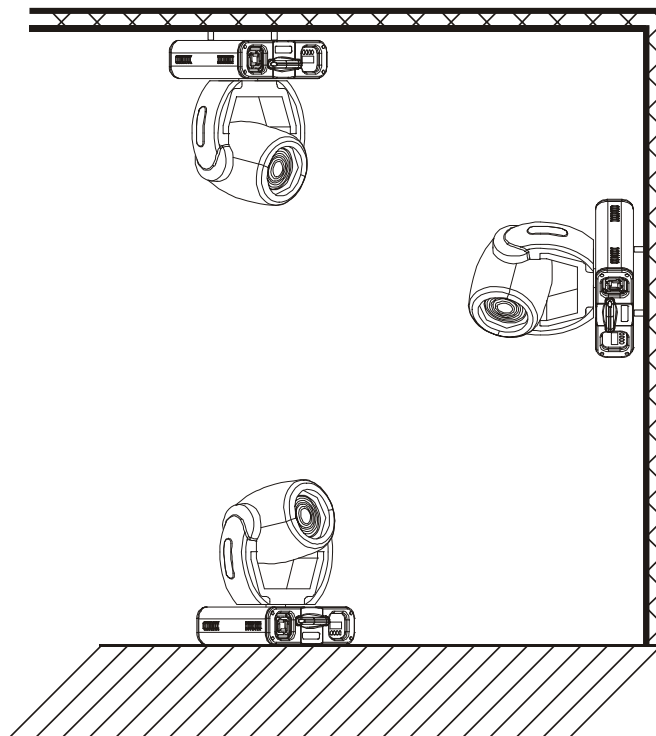

Pay attention to the regulations of: BGV C1 (former VBG 70) and DIN VDE 0711-217 !
The installation should be done by qualified staff only.

2.1.1 Clamps

Use two clamps on the backside of the **YPOC COLOR Basic** to mount the unit on a truss (each two opposite threads max. M10x20). See also printing on the backside of the case.

2.1.2 Mounting plate

For a permanent installation of the **YPOC COLOR Basic** you can use a optional mounting plate to fix the unit on a wall. The plate uses 4x screws M6x20.

2.2 Secure the YPOC COLOR Basic

Regardless of the rigging of the **YPOC COLOR Basic** you have to use a stipulated safety wire. Therefore you have to thread to safety wire through to two provided holes on the backside of the fixture and connect it with the truss-support. Pay attention to a safe and proper fastening.

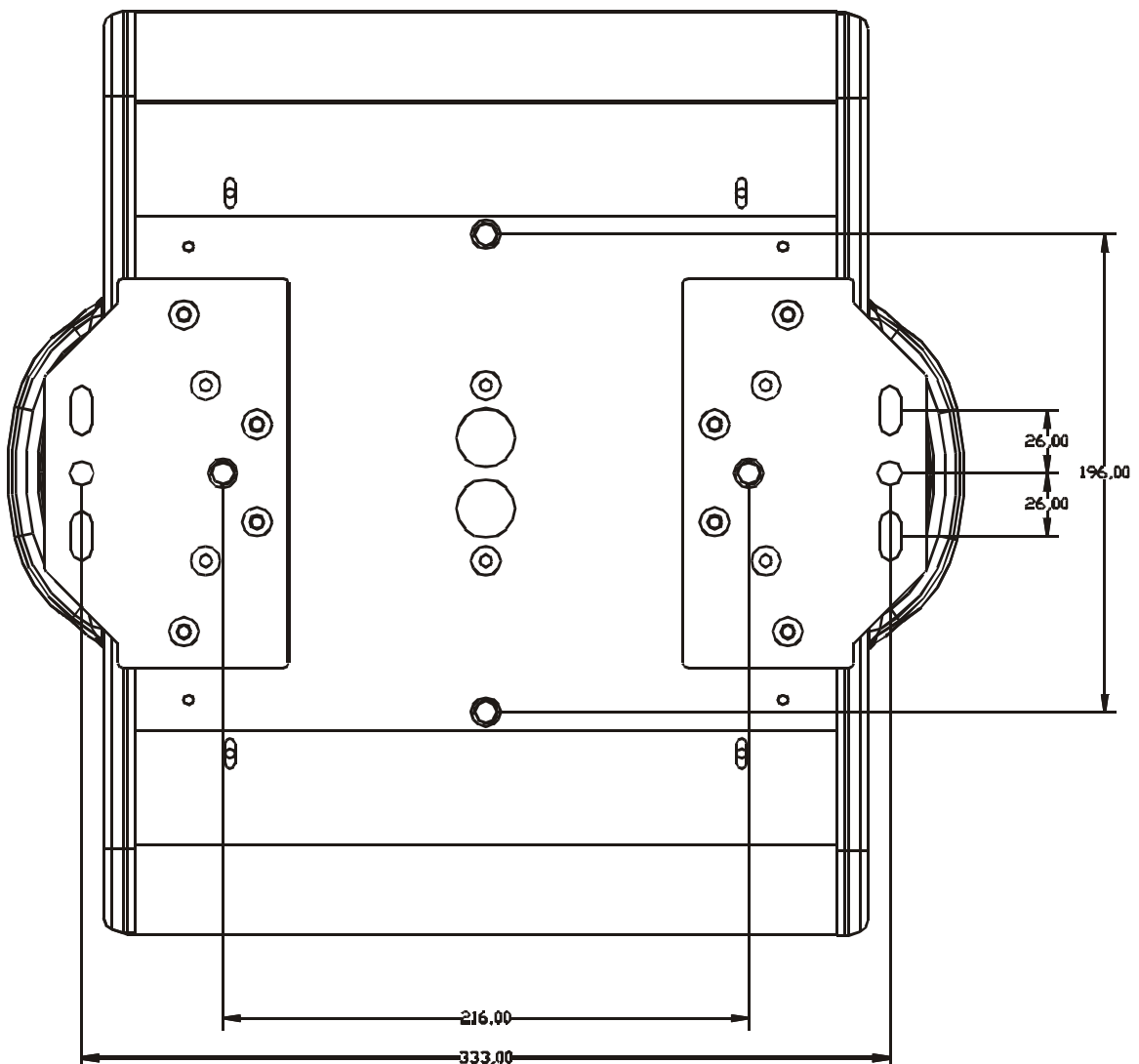

2.3 Connections

2.3.1 Power supply

230 Volt, 50 Hz,

Connected load 500W \Leftrightarrow 2,2 A (blind current compensation).

or 115V, 60 Hz

Connected load 500W \Leftrightarrow 4,4 A (blind current compensation).

Please see printing on the case for the right Power supply!

2.3.2 DMX

DMX 512 Standard input/output. See also printing on the case for the right pin assignment.

[+] = Pin 3 / [-] = Pin 2 / [Ground] = Pin 1

The DMX- Addressing starts at the DMX- Address [001].

2.4 Fuse

The **YPOC COLOR Basic** electronic system is protected by a 5x20 mm fuse.

230V / T 3,15A (EU model) or 115V / T 6,3A (US model)

Please see the printing on the **YPOC COLOR Basic** for more details.

Attention:

- **Disconnect AC outlet before changing a fuse!**
- **Use only the original declared fuse type!**

3 The Menu Field

You find the control board on the side part of the base. It allows you to make all necessary adjustments of the **YPOC COLOR Basic**. With the **Mode**-key you get into the main menu. Afterwards you can navigate through the menu with the **Up/Down**-keys. Push the **Enter**-key to get in the next menu level or to confirm your settings. Make them and set functions **ON/OFF** with the **Up/Down**-keys. Confirm and save it with the **Enter**-key (the display shows *OK*). Push the **Mode**-key to cancel the entry and go back to the main menu.

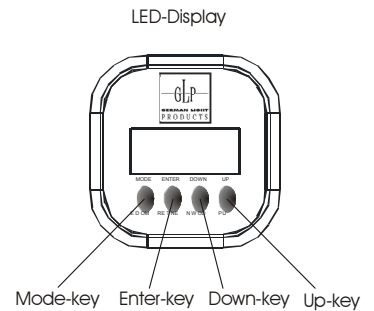

Level 1	Level 2	Level 3	Remark
DMX I			Define the DMX start address
TEST			Test program of all functions
AUDI	ASLW		Self-running audio program (slow)
	AFST		Self-running audio program (fast)
	MSTR		Master for the audio program
	S\PT		Basic position for the audio program
	SIZE		Size for the audio program (NORM-BIG-MIDL-SMAL)
LAMP			Switch on/of the lamp direct at the YPOC COLOR Basic
RESE			Reset
TIME	POWR		Running time of the fixture (no destructible)
	LA 1		Running time of the lamp (erasable)
	LA 2		Running time of the lamp (no destructible)
FCOL			Continuously movement of the color wheel
R PAN			Reverse Pan-direction
RTL T			Reverse Tilt-direction
SPEC	MANU		Manual drive of all device functions
	LARU		Automatic lamp start
	DMX I		Switch off lamp via DMX
	DMX I		Reed out actual DMX-values
	DISP	ON	Display On/Off
		REV	Twist the display
	TEMP		Reed out internal temperature
	FANS	HIGH	Maximum cooling fan velocity
		REG	Automatic cooling fan control
		LOOF	Low cooling fan speed → lamp off
		LOHI	Low cooling fan speed → automatic
	ADJU	CODE	Use the code for entering the calibration menu (for authorized person only)
		XXXX	Calibration of the color wheel
		COLO	Settings in the internal memory (superuser only)
		CLRE	Must read <i>ON</i> . Protected by a code
		FACC	Adjust- Rest
		ARES	Call on the default function values
	DFSE		Pan/Tilt feedback (error correction) On/Off
	FEEJ		Correction of faults
	EFLG		

3.1 Adjust the DMX- Address [100]

Right after turning on the **YPOC COLOR Basic** you can see the current DMX-Address. If there is no DMX- Signal the display flashes.



For the address setting please follow this procedure:

1. Switch On the **YPOC COLOR Basic** and wait until the fixture reset has finished ('**RESE**' is flashing in the display).
2. Press the **Mode**-key in order to access the main menu. Browse through the menu by pressing the **Up/Down**-keys until the display shows **100** . Confirm by pressing the **Enter**-key (the decimal point is flashing)
3. Use the **Up/Down**-keys to select the desired address. Confirm the setting by pressing the **Enter**-key (the display shows **OK**) or press the **Mode**-key to cancel.

The DMX- Address is stored also while switching off the **YPOC COLOR Basic!**

3.2 The Test Program [TEST]



The **Test**-Program allows you to run a complete self test procedure of all functions. Press **Enter** to confirm or **Mode** to cancel.

3.3 The Audio Program [AUDI]

The **Audio**-menu allows you to run a stand alone audio program. This chaser can run either fast or slow. **AFST**: Every sound impulse on step of the chaser. **ASLW**: Every second sound impulse one step of the chaser.

Additional you can choose a basic position for this audio chaser. Use therefore either the internal manual mode or an external controller to set the desired Pan/Tilt position. Confirm this setting in the **SPCT** menu by pressing the **Enter**-key.

You can also set the size of the audio chaser in the **SIZE** menu. You have the choice between: **NORM** (no basic position has to be chosen), '**BIG**', '**MIDL**' and '**SMAL**').

If you want to run the systems simultaneously, one of the **YPOCs** must be

switched as the master. All others must be "Slave" Master = OFF. **Notice:** The Audio function is only working when **no** DMX is connected. This function can work e.g. on small events or as an emergency program.

3.4 Lamp On/Off [LAMP]

LAMP

Use the **Up/Down**-keys to select lamp **ON** or lamp **OFF** Press **Enter** to confirm or **Mode** to cancel and return to the main menu. (The lamp **OFF** command is only working if the shutter is closed at the same time. Use an external controller or the manual drive mode, see 3.10.1 on page 13.

3.5 Reset [RESE]

RESE

Press the **Enter**-key to run a reset of all fixture functions (**RST** is shown in the display).

3.6 Running time of lamp and unit [TIME]

TIME

By this option can read out three different running times of the fixture.

POWR	Running time of the fixture (no destructible).
LA 1	Running time of the lamp (erasable). Push the Up/Down -keys at one time to delete this running time.
LA 2	Running time of the lamp (no destructible).

3.7 Continuous Color Wheel [FCOL]

FCOL

This function allows you to control the color wheel continuously. If it is switched off, the color wheel is stepping directly from one to another color.

3.8 Invert Pan Movement [RPAI]

RPAI

This function allows you to invert the Pan movement. Use the **Up/Down**-keys to select invert *ON* or *OFF*. Press **Enter** to confirm or **Mode** to cancel and return to the main menu.

3.9 Invert Tilt Movement (RTL T)

RTL T

This function allows you to invert the Tilt movement. Use the **Up/Down**-keys to select invert *ON* or *OFF*. Press **Enter** to confirm or **Mode** to cancel.

3.10 Special Functions (SPEC)

SPEC

This menu allows you to enter further special functions of the **YPOC COLOR Basic**.

In detail they are:

3.10.1 Manual Drive (MANU)

MANU

This function allows you to drive all the fixture functions manually. Select the desired function with the **Up/Down**-keys and confirm with **Enter**. Now choose the desired value with the **Up/Down**-keys and confirm again with **Enter** or cancel and return to the menu with the **Mode**-key.

Function	Value	Remark
PAN	000 - 255	Pan Position
TILT	000 - 255	Tilt Position
COLO	000 - 255	Color wheel (fixed colors)
SHUT	000 - 255	Shutter / Strobe function (the lamp strikes at DMX 255 if dimmer is "open" = DMX 255)
DIMR	000 - 255	Dimmer
SPEC	000 - 255	Lamp Off, Reset, ...

3.10.2 Lamp On automatically (LAAU)

LAAU

This function enables to switch On the lamp automatically after switching On the fixture. Use the **Up/Down**-keys to select **ON** if you want to switch on the lamp automatically after switching on the fixture or **OFF** if you don't want this function. Press **Enter** to confirm or **Mode** to cancel and return to the menu. If you have chosen **OFF** you have the possibility to start the lamp either via DMX or direct at the **YPOC COLOR Basic** in the Lamp menu.

3.10.3 Lamp Off via DMX [DLOF]

DLOF

This function enables to switch off the lamp via DMX or not. Use the **Up/Down**-keys to select **ON** if you want to switch off the lamp via DMX or **OFF** if you don't want this function. Press **Enter** to confirm or **Mode** to cancel and return to the menu.

3.10.4 DMX Input [DMX I]

DMX I

Readout DMX values of each channel received by the fixture. Use the **Up/Down**-keys to select desired channel and press **Enter** to read its value.

Function	Value	Remark
PAN	0 - 255	Pan Position
TILT	0 - 255	Tilt Position
COLO	0 - 255	Color wheel (fixed colors)
SHUT	0 - 255	Shutter / Strobe function
SPEC	0 - 255	Lamp OFF, Reset, ...
MOVE	0 - 255	Movement
SPEED	0 - 255	Speed Pan/Tilt

3.10.5 Display [DISP]

DISP

Use this function to choose between different display indications. Use the **Up/Down**-keys to select desired function and press **Enter** to confirm or **Mode** to cancel and return to the menu.

ON	Display On/Off (If you've chosen <i>OFF</i> , the display will go out within 15 seconds after the last input. The next key touch will reactivate the display).
REV	Turn around the display

3.10.6 Fixture Temperature [TEMP]

TEMP

This function allows you to read out the actual temperature of the **YPOC COLOR Basic**. Press **Enter** to confirm or **Mode** to cancel. Inside temperatures below 80°C are not critical. 80°C and more lead the lamp being switched off at a critical point. Please note for a save operation that the outside temperature should not exceed 45°C.

3.10.7 Fan Control [FANS]

FANS

By using this function you can choose between 4 types of fan speed operations. Use the **Up/Down**-keys to select desired function and press **Enter** to confirm or **Mode** to cancel and return to the menu.

HIGH	The cooling fan works continuously at max. speed.
REG	The fan automatically raises its speed in order to control inside temperature of the fixture.
LOOF	The fan keeps the adjusted low speed until the temperature exceeds max. inside temperature, then the YPOC COLOR Basic automatically switch off the lamp.
LOHI	The fan keeps the adjusted low speed until the temperature exceeds max. inside temperature, then the YPOC COLOR Basic automatically switch from low to high fan speed.

3.10.8 Adjustments and Calibrations [ADJU]

ADJU

By this function you can adjust and calibrate the positions of the different wheels and other motors. This can be necessary after a service or repair work.

For this function you have to enter the fixture code. This work should be done only by authorized persons.

Use the **Up/Down**-keys to select desired function and press **Enter** to confirm or **Mode** to cancel and return to the menu. Use now the **Up/Down**-keys to set the adjustment values and confirm once more with the **Enter**-key or cancel with the **Mode**-key.

Function	Value	Remark
<i>COLO</i>	<i>- 99 - + 99</i>	Color wheel
<i>CLRE</i>	Adjustments in the internal circuit.	For authorized persons only → Service manual
<i>FACC</i>	Must read <i>ON</i>	
<i>ARES</i>	Adjust- Reset	

3.10.9 Default Settings [DFSE]

DFSE

Press **Enter** to reset all fixture personalities (not the adjusted functions) to the default values. On the display will appear **OK** to indicate that the defaults are set.

Function	Display	Default Settings	
DMX Address	<i>1001</i>	<i>1001</i>	
Pan reverse	<i>R PAN</i>	<i>ON</i>	<i>OFF ✓</i>
Tilt reverse	<i>RTL T</i>	<i>ON</i>	<i>OFF ✓</i>
Automatic lamp on	<i>L A A U</i>	<i>ON</i>	<i>OFF ✓</i>
Lamp on via DMX	<i>1 L O F</i>	<i>ON ✓</i>	<i>OFF</i>
Display	<i>1 I S P</i>	<i>1 ON ✓</i>	
Cooling fan	<i>F A N S</i>	<i>HIGH</i>	<i>REG ✓</i>
Feedback	<i>F E E D</i>	<i>LOOF</i>	<i>LOHI</i>
		<i>ON ✓</i>	<i>OFF</i>

3.10.10 Feedback [FEE]]

FEE]]

The **YPOC COLOR Basic** is provided with a automatic position correction (feedback) for the Pan and Tilt movement. Use the **Up/Down**-keys to select **ON** if you want to enable the feedback function or **OFF** if you don't want this function. Press **Enter** to confirm or **Mode** to cancel and return to the menu.

3.10.11 Correction of faults [EFL]]

EFLG

(Function available for authorized persons only)

3.11 Error and Information Messages

HEAT	This message appears if you try to switch on the lamp within 5 minutes after having switched off (lamp too hot). The message will appear on the display if the lamp doesn't ignite within 20 seconds. The fixture will store this command and automatically ignite the lamp after 5 minutes.
LAER	After the ignition of the lamp was two times not successful the display will show LAER . That means the lamp could be damaged or even missed, the fixture is overheating or there could be a failure on the igniter or ballast. Switch off the power supply and solve the possible problem.
OTMP	This error message informs you that the fixture was overheating and that the relay switches off the lamp. Please look for possible reasons (fan faulty, air in/outlets blocked or very dirty, lamp broken or very old, too high ambient temperature). Switch off the power supply and solve the possible problem.
RSER	This message informs you that one of the fixture function wasn't able to do its reset correct (magnetic sensor, stepping motor, driver on the PCB, cables, etc.). Repair the defect and start the fixture again.

4 DMX Channel Selection (DMX Protocol)

Channel	Function	Time and Value	DMX	HEX	%
1) PAN-coarse	0 .. 530°	min. 2.65 s	0..255	00..FF	0..100
2) PAN-fine	Low- Pos ... High- Pos + 2.1° (16 Bit)		0..255	00..FF	0..100
3) Tilt-coarse	0 .. 285°	min. 1.8 s	0..255	00..FF	0..100
4) Tilt-fine	Low- Pos ... High- Pos + 1.1° (16 Bit)		0..255	00..FF	0..100
5) Color*	open (fast)	Chaser from color to color max. 140 BPM → 0,43 s	0..3	00..03	0,2
	color 1, Brilliant Blue (fast)		4..7	04..07	1,8
	color 2, Blue (fast)		8..11	08..0B	3,3
	color 3, Blue Purple (fast)		12..15	0C..0F	4,9
	color 4, Magenta (fast)		16..19	10..13	6,5
	color 5, Pink (fast)		20..23	14..17	8,0
	color 6, Orange (fast)		24..27	18..1B	9,6
	color 7, Canary (fast)		28..31	1C..1F	11,2
	color 8, Italian Blue (fast)		32..35	20..23	12,7
	color 9, Turquoise (fast)		36..39	24..27	14,3
	color 10, Jade (fast)		40..43	28..2B	15,9
	color 11, Red (fast)	44..47	2C..2F	17,5	
	open (fast)	48..63	30..3F	19,0	
	open (slow)	Chaser from color to color max. 70 BPM → 0,86 s	64..67	40..43	25,3
	color 1, Brilliant Blue (slow)		68..71	44..47	26,9
	color 2, Blue (slow)		72..75	48..4B	28,4
	color 3, Blue Purple (slow)		76..79	4C..4F	30,0
	color 4, Magenta (slow)		80..83	50..53	31,6
	color 5, Pink (slow)		84..87	54..57	33,1
	color 6, Orange (slow)		88..91	58..5B	34,7
	color 7, Canary (slow)		92..95	5C..5F	36,3
	color 8, Italian Blue (slow)		96..99	60..63	37,8
	color 9, Turquoise (slow)		100..103	64..67	39,4
	color 10, Jade (slow)		104..107	68..6B	41,0
	color 11, Red (slow)	108..111	6C..6F	42,5	
	open (slow)	112..127	70..7F	44,1	
color rotation, slow-fast, CW	min. 1.4 turns/h	128..191	80..BF	50..75	
color rotation, fast-slow, CCW	max. 2.9 turns/sec.	192..253	C0..FD	76..98	
Audio color chaser slow	each 4 th sound impulse → new color	254	FE	99	
Audio color chaser fast	each sound impulse → new color	255	FF	100	
6) Shutter	Shutter closed		0..15	00..0F	0..6
	Random Strobe (different pattern)		16..31	10..1F	7..11,9
	Strobe Pulse effect , slow - fast	min. frequency 0,7 Hz	32..47	20..2F	12..12,9
	Strobe effect , slow - fast	max. frequency 10 Hz	48..239	30..EF	13..93
	Shutter open		240..255	F0..FF	94..100
	Lamp ON (ignition)		254..255	FE..FF	99..100
7) Dimmer	Dimmer closed (0%)		0..3	0..3	0..1
	Dimmer 1%...99%	movement time 0,3 Sek.	4..251	4..FB	2..98
	Dimmer open (100%)		252..255	FC..FF	99..100
8) Special	No function		0..15	00..0F	0..6
	Rotating color chaser		32..63	20..3F	13..24
	Color chaser C / C+1 slow – fast		64..79	40..4F	25..31
	Color chaser C / C+2 slow – fast		80..95	50..5F	32..37
	PAN/Tilt chaser slow		96..111	60..6F	38..43

Channel	Function	Time and Value	DMX	HEX	%	
	PAN/Tilt chaser fast		112..127	70..7F	44..50	
	Lamp OFF (only if shutter is closed)!		230..249	E6..F9	92..97	
	Reset		250..255	FA..FF	98..100	
9) Movement	No movement		0	00	0	
	Movement	Size	Phase			
	PAN	1	0°	01..01	01..01	0,5
		1	90°	02..03	02..03	1,0
		1	180°	04..05	04..05	1,7
		1	270°	06..07	06..07	2,5
	PAN	2	0°	08..09	08..09	3,3
		2	90°	10..11	0A..0B	4,1
		2	180°	12..13	0C..0D	4,9
		2	270°	14..15	0E..0F	5,7
	PAN	3	0°	16..17	11..11	6,5
		3	90°	18..19	12..13	7,3
		3	180°	20..21	14..15	8,0
		3	270°	22..23	16..17	8,8
	PAN	4	0°	24..25	18..19	9,6
		4	90°	26..27	1A..1B	10,4
		4	180°	28..29	1C..1D	11,2
		4	270°	30..31	1E..1F	12
	TILT	size / phase see also PAN		32..63	20..3F	13..25
	PAN / TILT	size / phase see also PAN		64..95	40..5F	26..37
PAN / TILT (inverse)	size / phase see also PAN		96..127	60..7F	38..50	
Circle	size / phase see also PAN		128..159	80..9F	51..62	
Circle (inverse)	size / phase see also PAN		160..191	A0..BF	63..75	
lying eight	size / phase see also PAN		192..223	C0..DF	76..87	
random movement	size see also PAN		224..255	E0..FF	88..100	
10) Speed Pan/Tilt	Pan/Tilt relative movement		0..15	00..0F	0..6	
	Pan/Tilt slow – fast Use this channel 14) also for the speed of the movements (channel 13).	Pan Min. 530° = 200 s Pan Max. 530° = 2.65 s Tilt Min. 285° = 110 s Tilt Max. 285° = 1.8 s	16..255	10..FF	7..100	
Lamp ON	Shutter open		254..255	FE..FF	99..100	
Lamp OFF	Channel 8 (min. 3 sec.) (only if shutter is closed, channel 6 = 0 ..15)		230..249	E6..F9	92..97	

*) Set the function "FCOL" ON if you want to control the color wheel continuously.

5 Change the Lamp

For a frictionless operation please read this chapter carefully and follow all instructions.

5.1 Safety Regulations

- **Pull out the main plug!**
- Wait min. 20 minutes after the last operation to cool down the fixture.
- Don't touch the bulb of the lamp with bare fingers (this can cause damages).
- Before you put the **YPOC COLOR Basic** into operation close the casing, otherwise your retina can be hurt!

5.2 Realize the Lamp Change

1. **Pull out the main plug!**
2. Open the three screws on the backside of the unit.
3. Pull out the lamp sheet together with the lamp holder securely.
4. Remove the old or broken lamp out of the socket. **Attention:** The glass bulb of the lamp can splinter. For that reason remove the lamp with safety gloves or some cloth.
5. Put in the new lamp securely into the socket. **Attention:** Use only the original lamp type and do not touch the lamp with bare fingers.
6. Put the lamp sheet back into the unit.
7. Close the three screws.
8. Adjust the optimum light output with the three adjustment screws on the backside.
9. The running time of the lamp *LR I* can be reset in the *TIME* Menu.

6 Maintenance and Cleaning the YPOC COLOR Basic

It is absolutely essential that the fixture is kept clean and that dust, dirt and smoke-fluid residues must not build up on or within the fixture. Otherwise the fixture's light-output will be significantly reduced. Regular cleaning will not only ensure the maximum light-output, but will also allow the fixture to function reliably throughout its life.

A soft lint-free cloth moistened with any good glass cleaning fluid is recommended, under no circumstances should alcohol or solvents be used!

The inside optical system should be maintained only by authorized persons. Please contact your local dealer.

6.1 Safety Regulations

- **Pull out the main plug!**
- Wait min. 20 minutes after the last operation to cool down the fixture.
- Before you put the **YPOC COLOR Basic** into operation close the casing, otherwise your retina can be hurt!

6.2 Circumference and Interval (rule-of-thumb)

The contamination of the fixture depends on the environment details. Therefore no general guidelines can be given. From this it follows that the intervals are only suggestions from our practice experience.

Position	Interval	In this way
Outside optic	weekly	soft cloth and glass cleaning fluid
Color filter	monthly	soft cloth and glass cleaning fluid
Dimmer/Shutter	yearly	vacuum cleaner, airbrush, etc.
Fan and air channel	monthly	vacuum cleaner, airbrush, etc.
Reflector	yearly	soft cloth and glass cleaning fluid
Lampe	never	
Moveable parts	yearly	suitable fatty oil

Attention:

- **Never let optical parts come into contact with oil or fat.**
- **Before running the fixture wait until all parts are dried up.**

6.3 Cleaning the Optical System

1. Pull out the main plug!
2. Wait min. 20 minutes after the last operation to cool down the fixture.
3. Open the upper shell of the head casing by loosening the 4 Phillips screws.
Two on the front side and 2 on the back side of the head.
4. Do the work as explained in the list above.
5. Before you put the **YPOC COLOR Basic** into operation close the casing, otherwise your retina can be hurt!

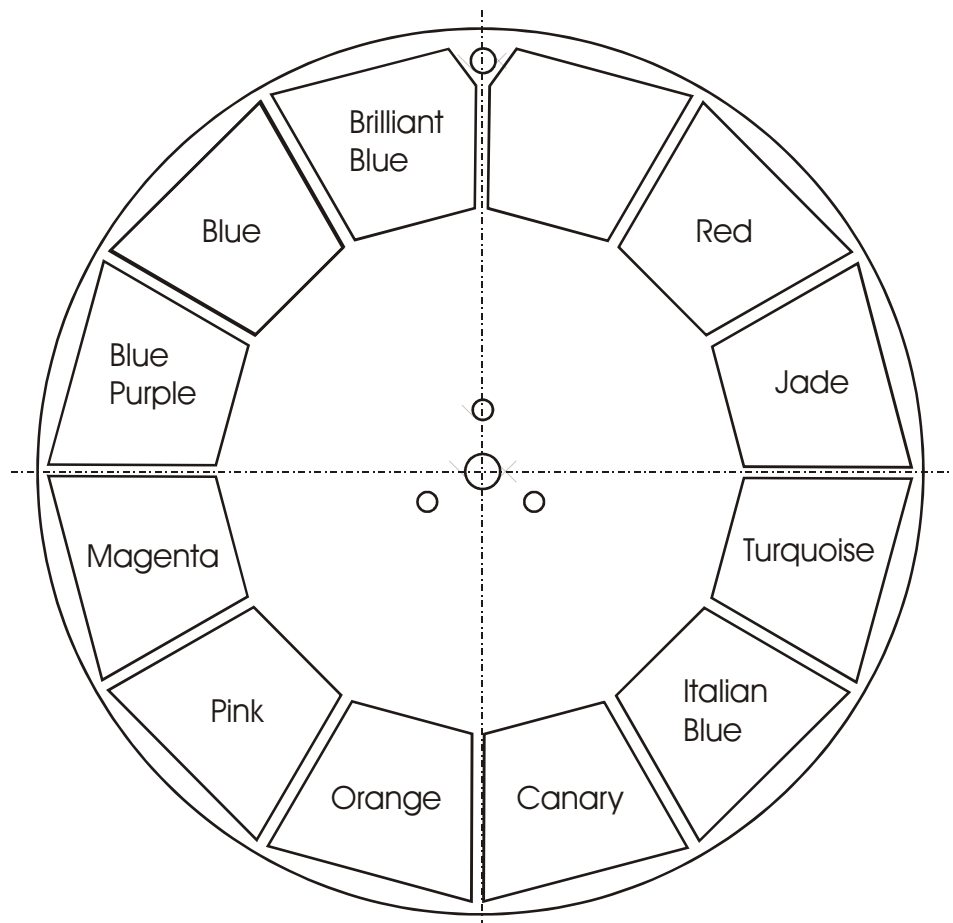

7 Technical Specification

Power supply	
Power consumption	500 Watt (blind current compensated)
EU- model	AC 230V / 50 Hz~
Fuse protection	T3,15A, 250V, 5x20 mm (fine-wire fuse)
US-model	AC 115V / 60 Hz~
Fuse protection	T6,3A, 115V, 5x20 mm (fine-wire fuse)
Lamp	
Types 1	MSD/HSD/CSD 230V/250W, socket GY-9,5
Type 2	MSD 230V/200W, socket GY-9,5
Optical system	
Aluminum reflector	
Fresnell lens 150mm	
Color	
11 dichroic filter plus white	
Mechanically adjustable Beam angel 8-22°	
Shutter / Strobe / Dimmer	
Strobe effect, variable in speed 1 – 10 flashes per second	
Continuously mechanical dimmer 0 - 100%	
Controlling	
Standard DMX-512, 3 pole XLR; [+] = Pin 3 [-] = Pin 2 [Ground] = Pin 1. The DMX addressing starts at the DMX- address [001].	
Pan / Tilt	
Pan- Movement	530° in max. 2,65 seconds, 16 Bit resolution
Tilt- Movement	280° in max. 1,68 seconds, 16 Bit resolution
Weights and measures	
Width of the base	380 mm
Length of the base	315 mm (390 mm incl. handles)
height (head vertical)	510 mm
Weight (net)	18 kg

8 Index

A

Audio Program 11

B

BGV C1 7
Blind current compensation..... 9

C

Calibrations 16
Circumference..... 21
Clamps 7
Connected load 9

D

Decoration..... 7
Default Settings 16
Description of Device 5
DIN VDE 0711-217 7
Display..... 15
DMX 9
DMX- Address 11
DMX Input 14
DMX Protocol 18

E

Error Messages 17

F

Fan 15
Fuse 9

I

Injury of the retina 6
Invert Pan/Tilt 12

L

Lamp Change..... 20

Lamp ON 19

M

Maintenance 20
Manual Drive 13
Measures 23
Menu Field 10
Mounting 7
Mounting plate 8

P

Pan- Movement 23
Power supply..... 9

R

Reset..... 12

S

Safety Instructions 6
Safety wire 8
Secure..... 8
Software version 1
Special Functions..... 13

T

Technical Specification 23
Temperature 15
Test Program 11

Tilt- Movement..... 23

V

VBG 70 7

W

Weight..... 23

